

General Description

The AAT3369-1 is a low-noise, constant-frequency charge pump DC/DC converter that uses a dual-mode load switch (1x) and fractional (1.5x) conversion to maximize efficiency for white LED CAB (Content Adaptive Brightness Control) applications. The AAT3369-1 is capable of driving 6 white LEDs at a total 126mA in a wide input range. The current sinks may be operated individually or in parallel for driving higher-current LEDs. A low external parts count (two 1µF flying capacitors and two small 1µF capacitors at IN and OUTCP) makes the AAT3369-1 ideally suited for small battery-powered applications.

AnalogicTech's S²Cwire serial digital input is used to enable and set maximum current to one of 32 levels for the LEDs. The maximum LED current ranges from 21mA to 0.3mA. A PWM input can also be adopted to dim the LED current from the maximum LED current to 1% of maximum LED current by PWM frequencies up to 100kHz. Low level at both S²Cwire and PWM inputs shut-down the IC with less than 1µA input current.

Each output of the AAT3369-1 is equipped with built-in short-circuit protection and auto-recover when the fault condition is removed. The soft-start circuitry prevents excessive inrush current at start-up and mode transitions. The AAT3369-1 is available in the Pb-free, space-saving TQFN3x2.2-18L package, and operates over the -40°C to +85°C ambient temperature range.

Features

- 2.7V to 5.5V Supply Voltage Range
- Drives up to 6 LEDs with up to 21mA each
- 126mA of Total Drive Current
- Charge Pump with Automatic Switching Between 1x and 1.5x Modes
- Linear LED Output Control
 - S²C Interface: 32 Steps from 21mA to 0.3mA
 - PWM Interface: Up to 100kHz from 1% to 100% Duty Cycle
- < 1.0µA Input Current in Shutdown
- Small Application Circuit
- Short Circuit Protection
- 0.9MHz Constant Frequency
- Automatic Soft-Start Limits Inrush Current
- -40°C to 85°C Temperature Range
- RoHS Compliant and Halogen Free TQFN3x2.2-18L Package

Applications

- Camera Phone
- LED Photo Flash/Torch
- MP3/MP4 Players
- PDAs and Notebook PCs
- Smart Phone

Typical Application

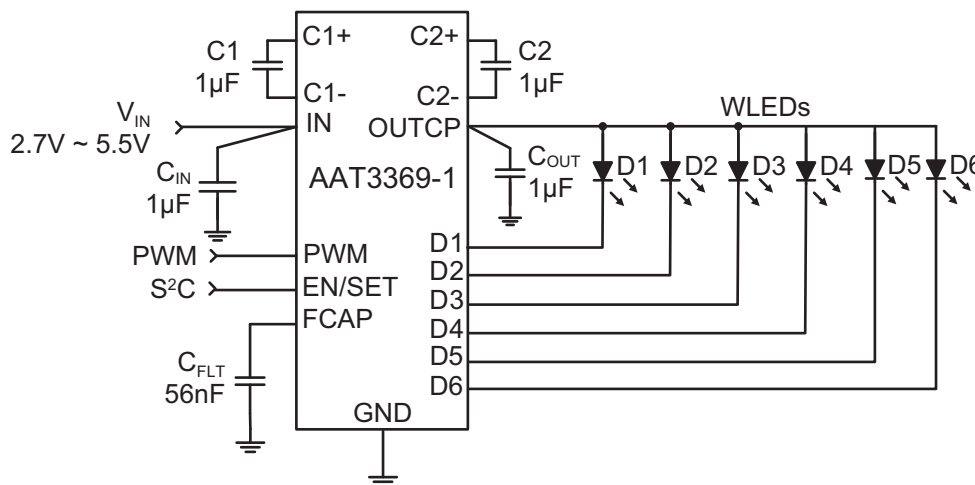

Pin Descriptions

Pin #	Symbol	Function	Description
1, 18	OUTCP	O	Charge-pump output. Connect a 1 μ F bypass capacitor between this pin to ground.
2	C1-	I	Flying capacitor C1 negative terminal. Connect a 1.0 μ F capacitor between C1+ and C1-.
3	C1+	I	Flying capacitor C1 positive terminal. Connect a 1.0 μ F capacitor between C1+ and C1-.
4	C2-	I	Flying capacitor C2 negative terminal. Connect a 1.0 μ F capacitor between C2+ and C2-.
5	N/C		Not connected.
6	IN	P	Input power supply pin. Connect a 1 μ F bypass capacitor from this pin to ground.
7	GND	PG	Ground connection.
8	PWM	I	PWM signal input. Connect a PWM signal to dim the LED current linearly from the max LED current set by S ² Cwire to 1% by PWM duty cycle. The default max LED current is 21mA when EN/SET is low. The frequency of the PWM signal may be up to 100kHz. Tie to ground if PWM is not used.
9	FCAP	I	PWM filter capacitor. For 50kHz PWM signal, a 56nF capacitor is recommended. If PWM control is not used, leave this pin open.
10	D1	I	LED driver current sink terminal D1. Connect LED cathode to this pin. Tie to OUTCP if not used.
11	D2	I	LED driver current sink terminal D2. Connect LED cathode to this pin. Tie to OUTCP if not used.
12	D3	I	LED driver current sink terminal D3. Connect LED cathode to this pin. Tie to OUTCP if not used.
13	D4	I	LED driver current sink terminal D4. Connect LED cathode to this pin. Tie to OUTCP if not used.
14	D5	I	LED driver current sink terminal D5. Connect LED cathode to this pin. Tie to OUTCP if not used.
15	D6	I	LED driver current sink terminal D6. Connect LED cathode to this pin. Tie to OUTCP if not used.
16	EN/SET	I	Charge pump max LED current enable/set input. Connect a S ² Cwire signal to set max LED current from 21mA to 0.2mA by 32 steps. Pull low together with PWM low to shut down AAT3369-1 with less than 1 μ A input current. Tie to ground if not used.
17	C2+ EP	I	Flying capacitor C2 positive terminal. Connect a 1.0 μ F capacitor between C2+ and C2-. Exposed pad. Connect to ground directly beneath the package.

Pin Configuration

TQFN3x2.2-18
(Top View)

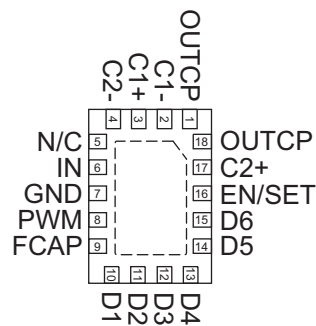

Absolute Maximum Ratings¹

T_A = 25°C unless otherwise noted.

Symbol	Description	Value	Units
V _{IN}	Input Voltage	-0.3 to 6.0	V
V _{EN}	EN/SET, PWM to GND Voltage	-0.3 to 6.0	V
I _{OUT}	Maximum DC Output Current (continuous) ²	200	mA
T _J	Maximum Junction Operating temperature	-40 to 150	°C
T _S	Storage Temperature Range	-65 to 150	°C
T _{LEAD}	Maximum Soldering Temperature (at leads, 10 sec)	300	°C

Thermal Information³

Symbol	Description	Value	Units
θ _{JA}	Thermal Resistance from Junction to Ambient	65.83	°C/W
θ _{JC}	Thermal Resistance from Junction to Case	38.90	°C/W
P _D	Maximum Power Dissipation	1.5	W

1. Stresses above those listed in Absolute Maximum Ratings may cause permanent damage to the device. Functional operation at conditions other than the operating conditions specified is not implied. Only one Absolute Maximum Rating should be applied at any one time.

2. Based on long-term current density limitation.

3. Mounted on an FR4 board.

ChargePump™ High Efficiency, 6 Channel, 1X/1.5X Charge Pump for White LED Applications
Electrical Characteristics¹

$V_{IN} = 3.6V$; $C_{IN} = 1\mu F$; $C_{OUT} = 1\mu F$; $C_{FLY} = 1\mu F$; $C_{FLT} = 56nF$; $T_A = -40^\circ C$ to $85^\circ C$, unless otherwise noted. Typical values are $T_A = 25^\circ C$.

Symbol	Description	Conditions	Min	Typ	Max	Units
Input Power Supply						
V_{IN}	Input Voltage Range		2.7		5.5	V
$V_{OUT(max)}$	Maximum Output Voltage			5.5		V
I_Q	Operating Current	1x Mode, No Load Current, CP enabled		0.5	1	mA
		1.5x Mode, $I_{D1} = FS$, excluding I_{D1} , $V_{D2} = V_{D3} = V_{D4} = V_{D5} = V_{D6} = IN$		2	4	
$I_{SHDN(MAX)}$	Shutdown Current	EN = 0			1.0	μA
Charge Pump Section						
$I_{OUT(MAX)}$	Maximum Output Current	$V_F = 3.6V$		186		mA
f_{osc}	Oscillator Frequency			0.9		MHz
t_{SS}	Charge Pump Set Up Time			100		μs
$V_{IN(TH)}$	Charge Pump Mode Hysteresis	1.5x to 1x Transition, $I_{D1} = I_{D2} = I_{D3} = I_{D4} = I_{D5} = I_{D6} = 21mA$		300		mV
LED Current Sink Outputs						
I_{DX}	I_{SINK} Current Accuracy ²	Data 1 and PWM = 100%, $T_A = 25^\circ C$	-10		+10	%
		Data 32 only, $T_A = 25^\circ C$		± 15		
$I_{DX(MATCH)}$	Current Marching Between Any Two Current Sinks ³	V_F ; D1:D6 = 3.6V	-5		+5	
$V_{D(TH)}$	Charge Pump Mode Transition	1x to 1.5x Mode, $I_{D1} = I_{D2} = I_{D3} = I_{D4} = I_{D5} = I_{D6} = 21mA$		200		mV
S²Cwire Control and EN/SET Control						
$V_{EN/SET(L)}$	EN/SET or PWM Input Low Threshold Voltage				0.4	V
$V_{EN/SET(H)}$	EN/SET or PWM Input High Threshold Voltage		1.4			V
I_{LEAK}	EN/SET Input Leakage		-1		1	mA
$t_{EN/SET(LOW)}$	EN/SET Input Low Time		0.3		75	μs
$t_{EN/SET(HI_MIN)}$	EN/SET Minimum High Time			50		ns
$t_{EN/SET(HIMAX)}$	EN/SET Maximum High Time				75	μs
$t_{EN/SET(OFF)}$	EN/SET Input Off Timeout ⁴				500	μs
$t_{EN/SET(LAT)}$	EN/SET Latch Timeout ⁵				500	μs
PWM Control						
$V_{PWM(L)}$	PWM Input Low Threshold Voltage				0.4	V
$V_{PWM(H)}$	PWM High Threshold Voltage		1.4			V
$T_{PWM(ON)}$	PWM Turn On Delay				500	μs
$F_{PWM(MIN)}$	PWM Minimum Input Control Frequency		100			Hz
$F_{PWM(MAX)}$	PWM Maximum Input Control Frequency			100		kHz
$F_{PWM(MIN)}$	PWM Minimum Duty Cycle	$F_{PWM} = 50kHz$, Full Scale	1			%
Thermal						
T_{SD}	T_J Thermal Shutdown Threshold			140		$^\circ C$
T_{HYS}	T_J Thermal Shutdown Hysteresis			20		

1. The AAT3369-1 is guaranteed to meet performance specifications over the $-40^\circ C$ to $+85^\circ C$ operating temperature range and is assured by design, characterization, and correlation with statistical process controls.

2. Determined by the average of all active channels.

3. Current matching is defined as the deviation of any sink current from the average of all active channels.

4. The EN/SET pin must remain logic low (less than V_{IL}) for the duration of longer than $500\mu s$ to guarantee the off timeout.

5. The EN/SET pin must remain logic high (greater than V_{IH}) for the duration of longer than $500\mu s$ to guarantee the latch timeout.

Typical Characteristics

**Operating Current vs. Input Voltage
(1x Mode)**

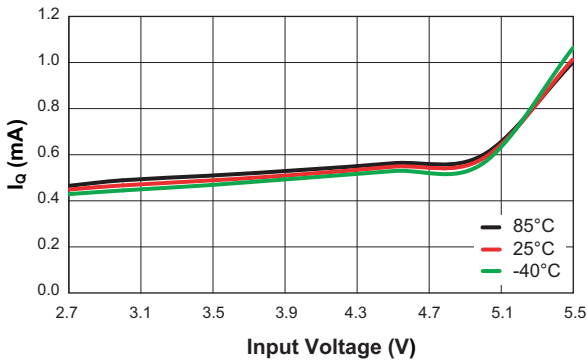

**Operating Current vs. Input Voltage
(1.5x Mode)**

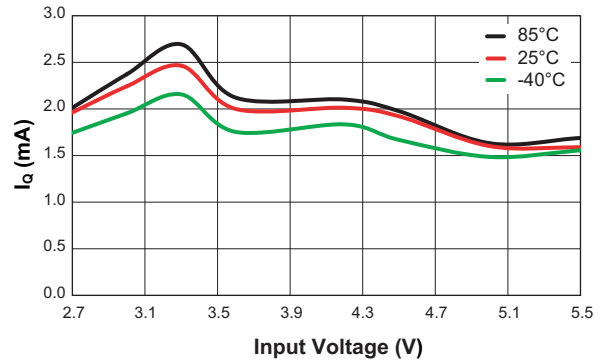

Input Current vs. Input Voltage

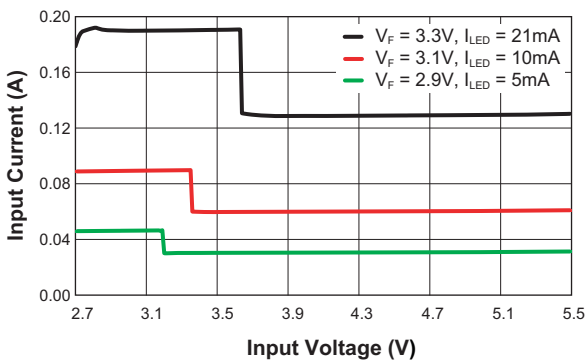

Shutdown Current vs. Temperature

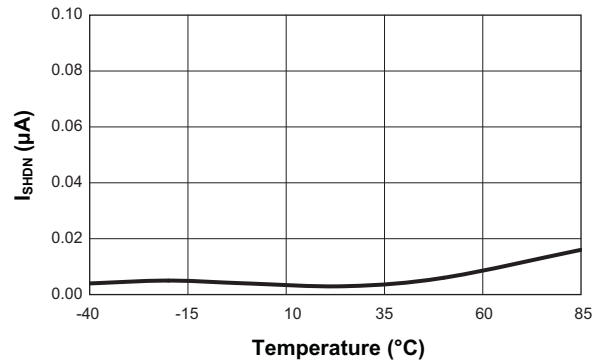

Efficiency vs. Input Voltage

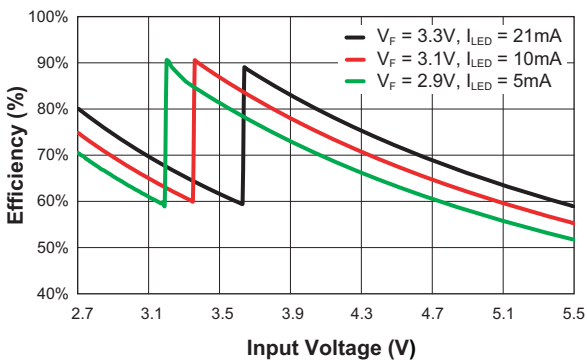

Frequency vs. Temperature

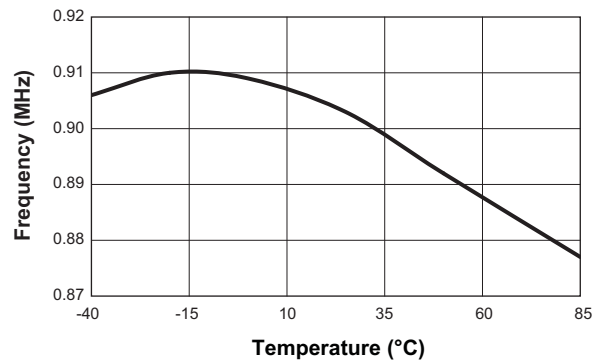

Typical Characteristics

Current Matching vs. Input Voltage
(S²C Data = 1)

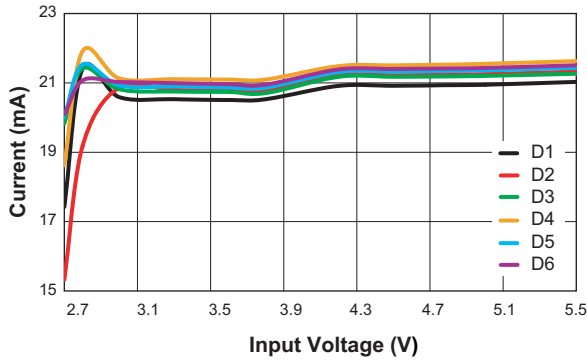

Current Matching vs. Input Voltage
(S²C Data = 32)

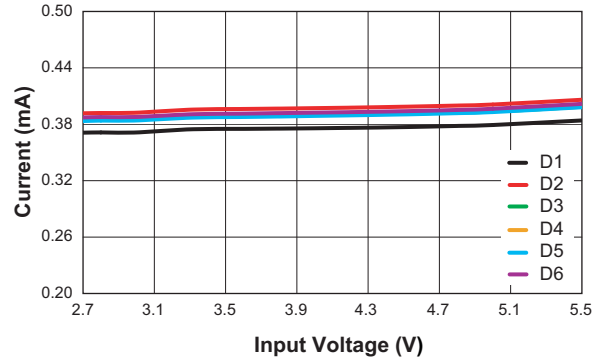

Current Matching vs. Temperature
(S²C Data = 1)

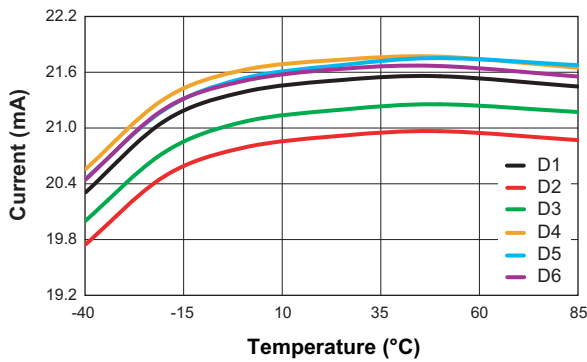

Current Matching vs. Temperature
(S²C Data = 32)

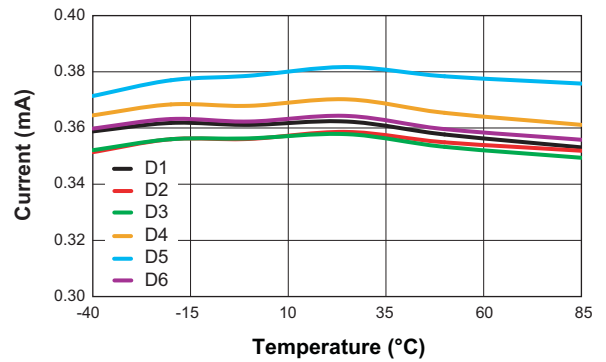

EN Input High Threshold Voltage vs. Input Voltage

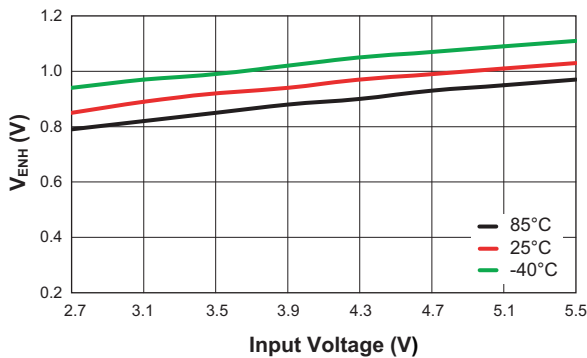

EN Input Low Threshold Voltage vs. Input Voltage

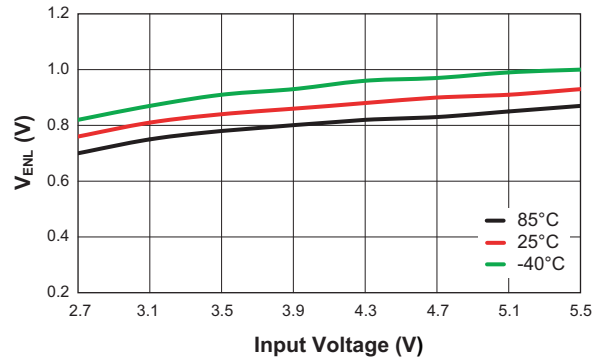

Typical Characteristics

EN/SET Input Latch Time vs. Input Voltage

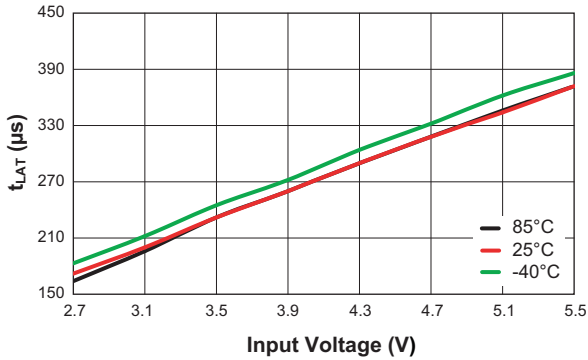

EN/SET Input OFF Time vs. Input Voltage

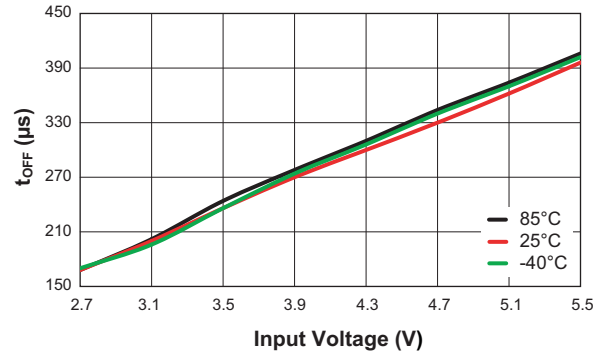

PWM Input High Threshold Voltage vs. Input Voltage

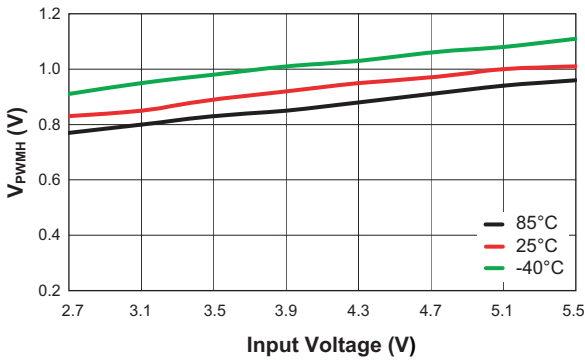

PWM Input Low Threshold Voltage vs. Input Voltage

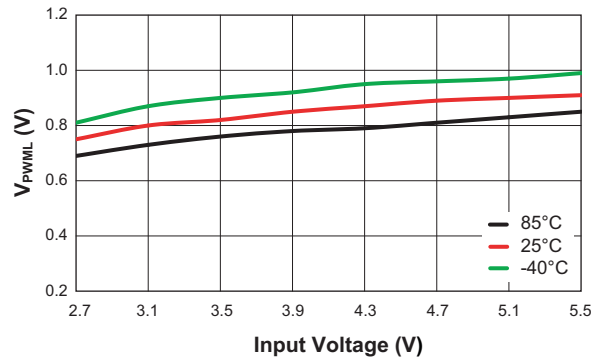

Turn On to 1x Mode

($V_{IN} = 4.2V$, $C_{IN} = C_{OUT} = 1\mu F$, $C_F = 56nF$, $21mA/Channel$)

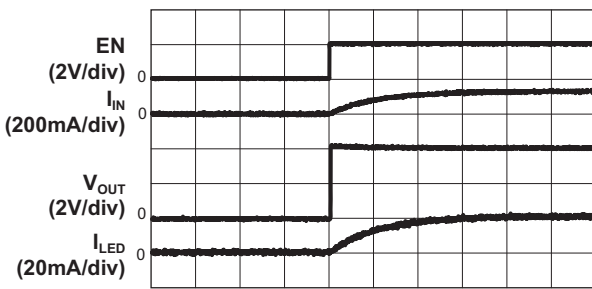

Time (20ms/div)

Turn On to 1.5x Mode

($V_{IN} = 3.6V$, $C_{IN} = C_{OUT} = 1\mu F$, $C_F = 56nF$, $21mA/Channel$)

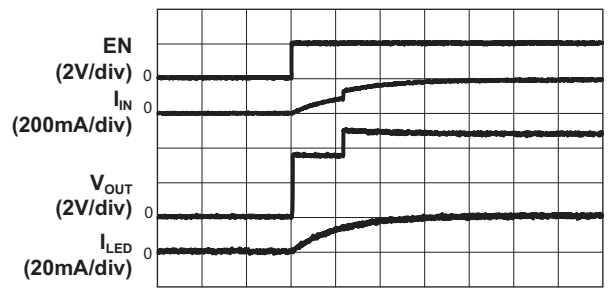

Time (20ms/div)

Typical Characteristics

Turn Off

($V_{IN} = 3.6V$, $C_{IN} = C_{OUT} = 1\mu F$, $C_F = 56nF$, 21mA/Channel)

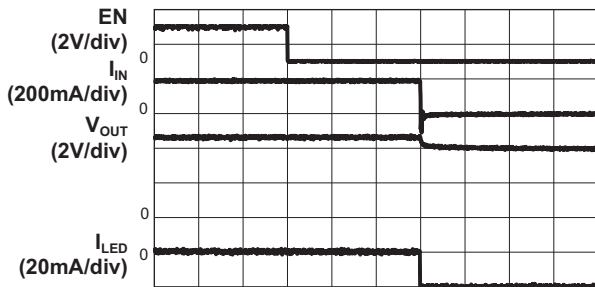

Time (100 μ s/div)

CP Mode Transient

($V_{IN} = 3.6V$ to 4.2V, $C_{IN} = C_{OUT} = 1\mu F$, 21mA/Channel)

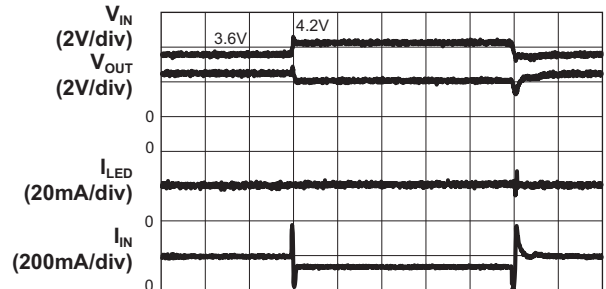

Time (100 μ s/div)

LED Current Transient

($V_{IN} = 3.6V$, $C_F = 56nF$, 0.4mA to 21mA)

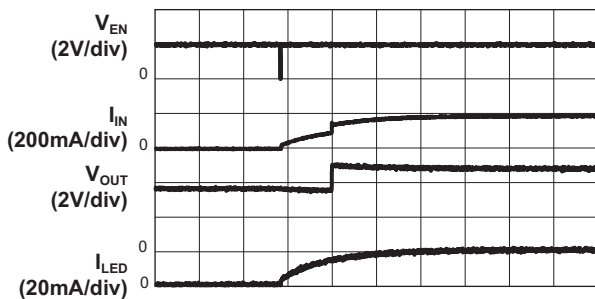

Time (20ms/div)

LED Current Transient

($V_{IN} = 3.6V$, 21mA to 0.4mA)

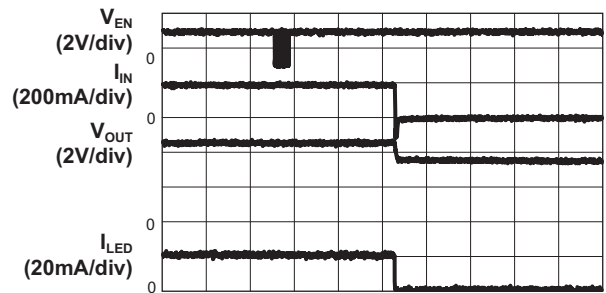

Time (100 μ s/div)

1.5x Mode Operating Characteristics

($V_{IN} = 3.6V$, $C_{IN} = C_{OUT} = 1\mu F$, S²C Control Mode, 21mA/Channel)

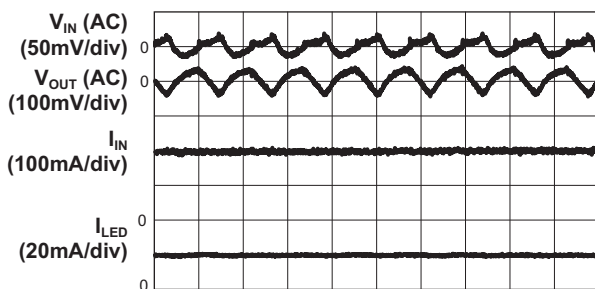

Time (1 μ s/div)

1.5x Mode Operating Characteristics

($V_{IN} = 3.6V$, $C_{IN} = C_{OUT} = 1\mu F$, PWM with 100kHz, 50% Duty Cycle)

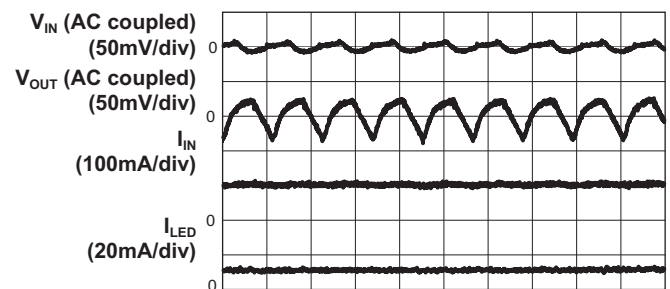

Time (1 μ s/div)

Functional Block Diagram

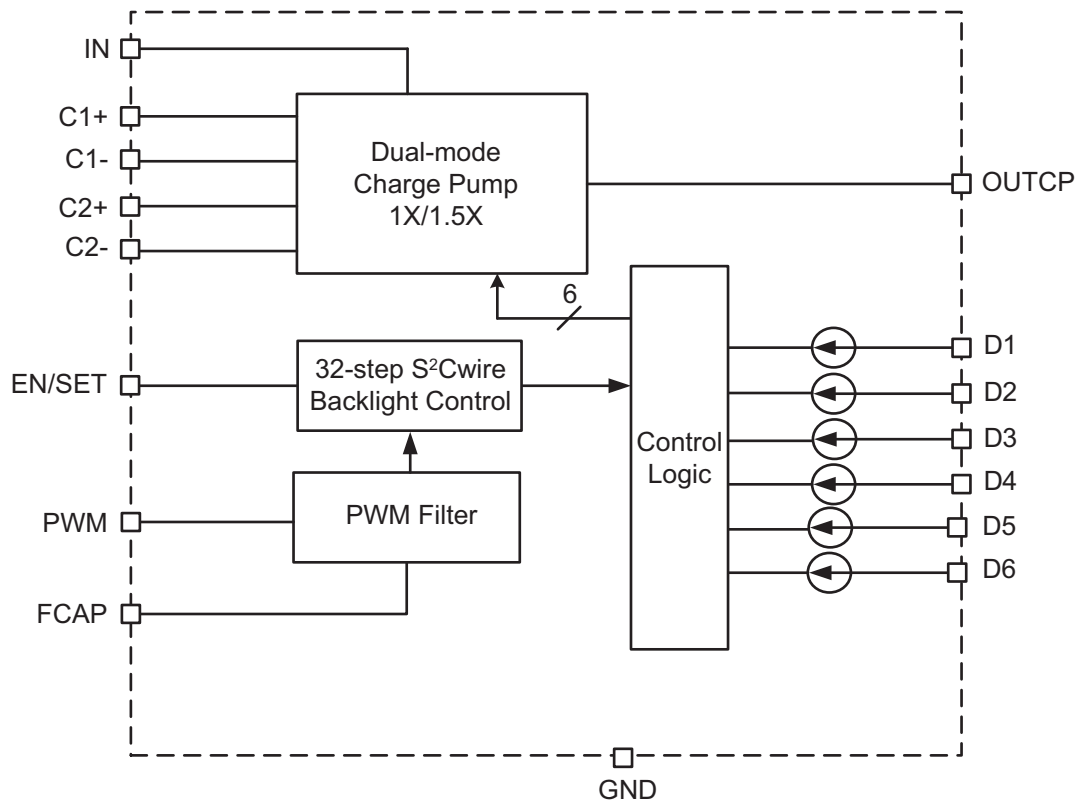

Functional Description

The AAT3369-1 is a high efficiency charge pump white LED driver for portable applications. It can drive 6 white LEDs.

The AAT3369-1 is a fractional charge pump and can multiply the input voltage by 1 or 1.5 times automatically. The charge pump switches at a fixed frequency of 0.9MHz. The internal mode-selection circuit automatically switches the mode between 1x and 1.5x based on the input voltage, output voltage and load current. This mode switching maximizes the efficiency throughout the entire LED load range.

When the input voltage is high enough, the AAT3369-1 operates in 1x mode (no charge pump) to provide maximum efficiency. If the input voltage is too low to supply the programmed LED current, typically when the battery discharges and the voltage decays, the 1.5x charge pump mode is automatically enabled. When the battery is connected to a charger and the input voltage become high enough again, the device will switch back to 1x mode.

The current sink magnitude is controlled by either the EN/SET serial data S²Cwire interface, a PWM interface or both. The S²Cwire interface records rising edges of the EN/SET pin and decodes them into 32 maximum individual current level settings from 21mA to 0.3mA each. The PWM interface receives an input switching frequency where the duty cycle is varied to dim or light the LED by changing the LED current between 100% and 1% of the maximum value for CABC applications to reduce or increase display power. To avoid switching noise and flicker in the output LED, the PWM input frequency is filtered via an internal resistor and small external capacitor to provide a continuous LED current. The AAT3369-1 is disabled by both EN/SET and PWM pulled low.

Current Level Settings

LED current level is set via AnalogicTech's Simple Serial Control (S²Cwire) interface in a linear scale where LED current of each code is smaller than the one of the previous code, as shown in Table 1. In this manner, the LED current decreases linearly with each increasing code.

S ² Cwire Data	LED Current (mA)	S ² Cwire Data	LED Current (mA)
1	21.0	17	10.2
2	20.3	18	9.5
3	19.6	19	8.8
4	19.0	20	8.1
5	18.3	21	7.5
6	17.6	22	6.8
7	16.9	23	6.1
8	16.3	24	5.4
9	15.6	25	4.7
10	14.9	26	4.1
11	14.2	27	3.4
12	13.5	28	2.7
13	12.9	29	2.0
14	12.2	30	1.4
15	11.5	31	0.7
16	10.8	32	0.3

Table 1: S²C Data vs. LED Current.¹

S²Cwire EN/SET Interface

The LED current magnitude is controlled by the EN/SET pin using the S²Cwire interface. The interface records rising edges of the EN/SET pin and decodes them into 32 individual current level settings. Code 1 is full scale (21mA), and Code 32 is 0.3mA. The modulo 32 interface wraps states back to state 1 after the 32nd clock. The counter can be clocked at speeds up to 0.9MHz, so intermediate states are not visible. The first rising edge of EN/SET enables the IC and initially sets the output LED current to full scale, the lowest setting equal to 0.3mA. Once the final clock cycle is input for the desired brightness level, the EN/SET pin should be held high to maintain the device output current at the programmed level. The device is disabled 500μs after the EN/SET and PWM pin enters a logic low state. The EN/SET timing is designed to

accommodate a wide range of data rates. After the first rising edge of EN/SET, the charge pump is enabled and reaches full capacity after the soft-start time (T_{SS}). Exact counts of clock pulses for the desired current level should be entered on the EN/SET pin with a single burst of clocks.

The counter refreshes each time a new burst clock input to the EN/SET pin is detected. A constant current is sunk as long as EN/SET remains in a logic high state. The current sink pins are switched off after EN/SET and PWM has remained low state for at least the t_{OFF} timeout period (see Figure 1).

PWM Control

The AAT3369-1 also includes a PWM input as an additional means of providing dimming control for CABC application. Before the PWM signal is activated the EN/SET pin must be held for the t_{LATCH} period which sets the maximum current available to the LEDs. For example, if the maximum current of 19.8mA is required, then three rising edges of the EN/SET followed by t_{LATCH} will allow 19.8mA to flow through the LED. By applying a variable duty cycle on the PWM pin this current can be adjusted. The minimum duty cycle is dependent upon the PWM frequency. Frequencies of up to 100kHz can be applied. To avoid output flicker and noise, the input control PWM frequency is filtered by an internal resistor in conjunction with an external filter capacitor. A 56nF ceramic capacitor is recommended.

To specify 21mA maximum LED current, there are two ways to realize the dimming. One is feeding a simple rising edge of EN/SET followed by t_{LATCH} , then applying a pulse width modulation signal to the PWM pin to control the dimming; the other is keeping EN/SET low and applying a PWM signal directly with the duty cycle between 100% and 1%.

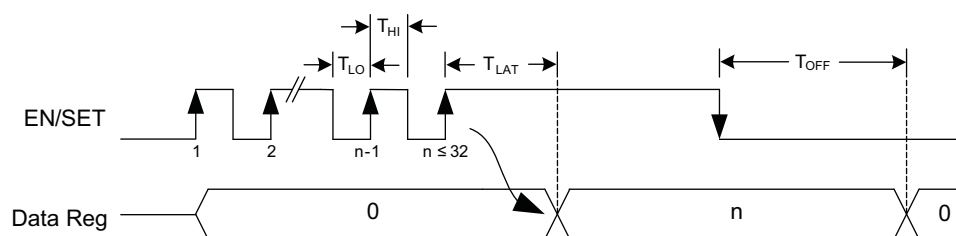
Figure 1: S²Cwire Timing Diagram When PWM is Low.

1. The LED current accuracy is compromised at high DATA settings.

Application Information

Setting LED Current

The AAT3369-1's six LED current channels can be programmed by S²Cwire, PWM or S²Cwire with PWM at the same time. Table 1 and Figure 2 shows 32 steps of LED current setting by S²Cwire through the EN/SET pin. When only the S²C wire interface is used, connect the PWM pin to ground.

LED current can also be programmed by PWM duty ratio control through the PWM pin when EN/SET is pulled low. The maximum LED current is 21mA at this condition. Up to 100kHz PWM signal is valid as the control signal. The high level duty ratio from 100% to 1% of the PWM signal controls the LED current linearly from 21mA to 1.1mA as shown in Figure 3. To get an ideal linear LED current control and avoid flicker, a suitable capacitor is required between FCAP and ground as C_{FLT}. The C_{FLT} value is related to the PWM frequency. Refer to the "Capacitor Selection" section of this datasheet to select a suitable capacitor to filter the PWM signal.

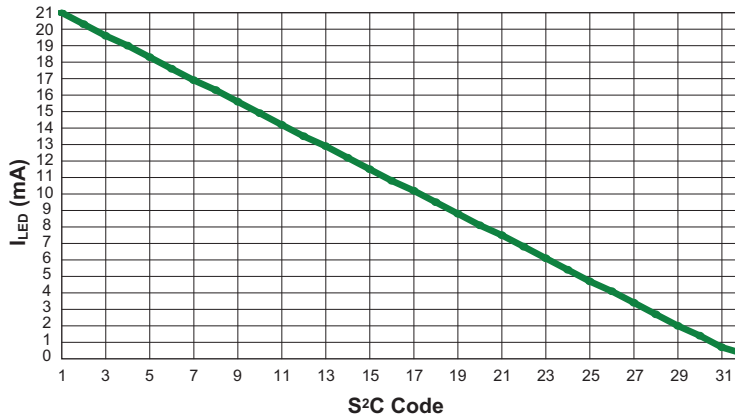

Figure 2: LED Current Controlled by S²Cwire Only.

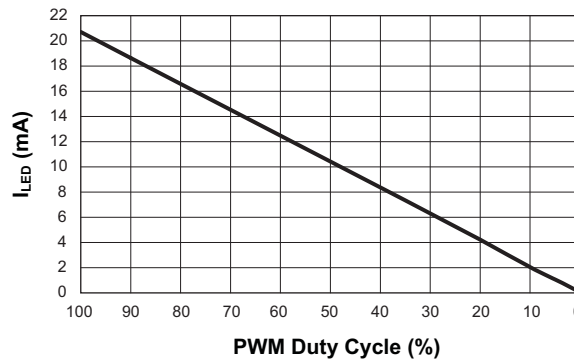

Figure 3: LED Current Controlled by PWM Duty Ratio Only.

ChargePump™ High Efficiency, 6 Channel, 1X/1.5X Charge Pump for White LED Applications

S²Cwire and PWM signal can work together to control the LED current. S²Cwire is used to set the maximum LED current by changing the data register, and varying the PWM duty ratio changes the LED current value between 100% of the maximum value and 1% of maximum. Figure 4 illustrates the timing requirement.

As an example, after three rising edges of S²Cwire and T_{LAT}, 19.6mA per channel maximum LED current is set. Up to 100kHz PWM signal is employed to change the LED constant current linearly from 19.6mA to 0.2mA by varying the PWM duty ratio from 100% to 1%.

Capacitor Selection

The AAT3369-1 requires five capacitors for a typical application: C_{IN}, C_{OUT}, C₁, C₂ and C_{FLT}. Among them, C_{IN}, C₁, C₂ and C_{OUT} are 1.5x mode charge pump necessary components. 1μF surface-mount multi-layer ceramic capacitors with less than 100mΩ Equivalent Series Resistance (ESR) are recommended. Though the ESR of the capacitors will not affect the ability of the capacitor to store energy, they have large effect on the performance such as equivalent output resistance, efficiency and output voltage ripple of

the charge pump. Tantalum and aluminum electrolytic capacitors are not recommended due to their high ESR. Some recommended capacitors are listed in Table 1.

Ceramic capacitors with X5R temperature characteristic are preferred for most AAT3369-1 applications. These capacitors have good capacitor tolerance over a wide temperature range (X5R: ±15% over -55°C to +85°C). Capacitors with Y5V or Z5U temperature characteristic are generally not recommended for AAT3369-1. They have wide capacitance tolerance over special temperature (Y5V: +22%, -82% over -30°C to +85°C, Z5U: +22%, -56% over +10°C to +85°C).

C_{FLT} is adopted as the capacitor of the RC filter to filter the PWM control signal to a constant voltage for internal LED current control. To internal 500kΩ R, and set the RC filter rejection frequency is 1/20 of the PWM frequency. The C_{FLT} minimum value can be calculated by the following formula:

$$C_{FLT} \geq \frac{20}{2\pi R \cdot f_{PWM}}$$

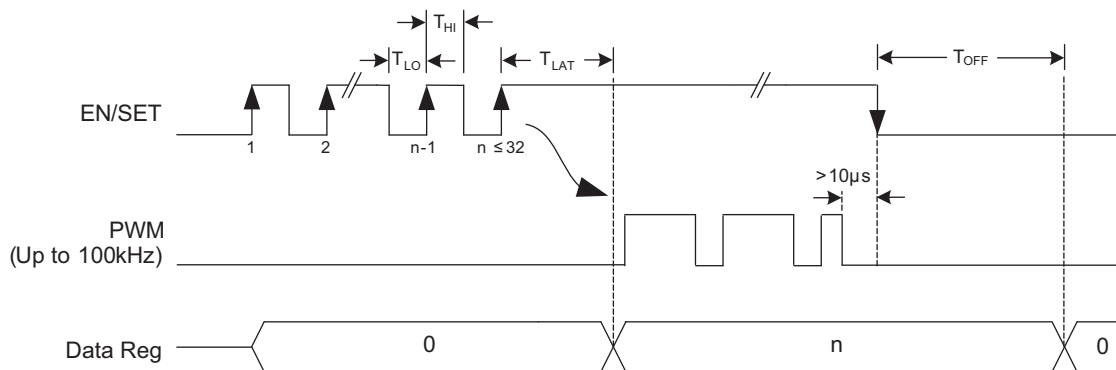

Figure 4: S²Cwire and PWM Control Timing.

Manufacturer	Part Number	Value (μF)	Voltage	Temp. Co.	ESR (mΩ) at 1MHz	Case
Murata	GRM188R61C105KA93	1	16	X5R	18	0603
	GRM185R60J105KE21	1	6.3	X5R	16	0603
TDK	C1608X5R1C105K	1	16	X5R	5.5	0603

Table 1: Capacitor Recommendation.

ChargePump™ High Efficiency, 6 Channel, 1X/1.5X Charge Pump for White LED Applications

Table 2 shows some minimum C_{FLT} values for different PWM frequency. For most application, 56nF is a suitable value. If PWM control is not used, C_{FLT} is unnecessary.

f_{PWM} (kHz)	Minimum C_{FLT} (nF)
0.1	59
1	6
10	0.6
30	0.2
50	0.1
80	0.08
100	0.06

Table 2. Minimum C_{FLT} Value Examples.

LED Selection

A good LED lighting application circuit is not only determined by the LED driver but also the LED selected. A higher luminous efficacy LED emits a higher amount of luminous flux (lumens) for a given power. Most LED manufacture datasheet provides the luminous efficacy by the luminous flux curve (LED forward current vs luminous flux). From the luminous flux curve, increasing the LED forward current may increase the LED light. While increased LED forward current also increases LED forward voltage with higher rating.

The AAT3369-1 is designed to drive high-intensity white LEDs. It is particularly suitable for LEDs with an operating forward voltage V_F in the range of 1.5V to 4.0V. To the white LEDs with lower forward voltage (V_F), it switches the charge pump mode 1x and 1.5x mode automatically to maintain the continuous LED current accuracy at lower input voltage and obtains higher efficiency at the mode transfer input voltage point.

Charge Pump Efficiency

1x Mode Efficiency

The AAT3369-1's 1x mode is operational at all times and functions alone to enhance device power conversion efficiency when V_{IN} is higher than the voltage across the load. When in 1x mode, voltage conversion efficiency is defined as output power divided by input power.

An expression for the ideal efficiency (η) in 1X charge pump mode can be expressed as:

$$\eta = \frac{P_{OUT}}{P_{IN}} = \frac{V_F \cdot I_{OUT}}{V_{IN} \cdot I_{IN}} \approx \frac{V_F}{V_{IN}}$$

-or-

$$\eta (\%) = \frac{V_F}{V_{IN}} \cdot 100$$

1.5x Charge Pump Mode Efficiency

The AAT3369-1 contains a fractional charge pump which will boost the input supply voltage in the event where V_{IN} is less than the voltage required to supply the output. The efficiency (η) can be simply defined as a linear voltage regulator with an effective output voltage that is equal to one and one half times the input voltage. Efficiency (η) for an ideal 1.5x charge pump can be calculated by the following equation:

$$\eta = \frac{P_{OUT}}{P_{IN}} = \frac{V_F \cdot I_{OUT}}{V_{IN} \cdot I_{IN}} = \frac{V_F \cdot I_{OUT}}{V_{IN} \cdot 1.5 \cdot I_{OUT}} \approx \frac{V_F}{1.5 \cdot V_{IN}}$$

-or-

$$\eta (\%) = \frac{V_F}{1.5 \cdot V_{IN}} \cdot 100$$

Thermal and Short Circuit Protection

When the device internal junction temperature reaches 125°C, the AAT3369-1 starts thermal protection by shutting down the charge pump. When the fault condition is removed and the junction temperature drops, the charge pump recovers automatically.

When OUTCP is fault by being shorted to ground, the AAT3369-1 protects itself by limiting the input current to below 600mA, and shuts down the charge pump if the current exceeds this value. It will recover to normal operation automatically when the fault condition is removed.

Additional Applications

The current sinks of the AAT3369-1 can be combined to drive higher current levels through a single LED. As an example, Figure 5 illustrates driving a single white LED with 186mA by connecting D1-D6 together to the LED cathode.

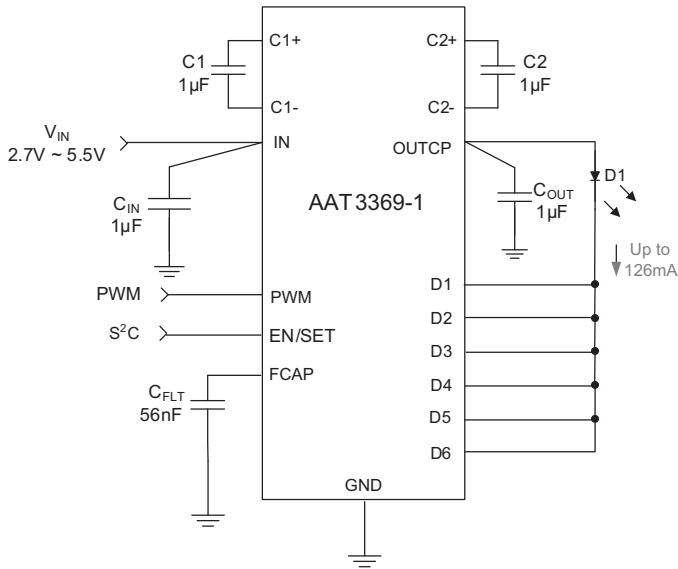

Figure 5: Higher Current, Single LED Application.

Printed Circuit Board Layout Recommendations

When designing a PCB for the AAT3369-1, the key requirements are:

1. Place the flying capacitors C1 and C2 as close to the chip as possible; otherwise 1.5x mode performance will be compromised.
2. Place input and output decoupling capacitors as close to the chip as possible to reduce switching noise and output ripple.
3. Connect the exposed pad to GND plane to get best power dissipation.

Schematic and Layout

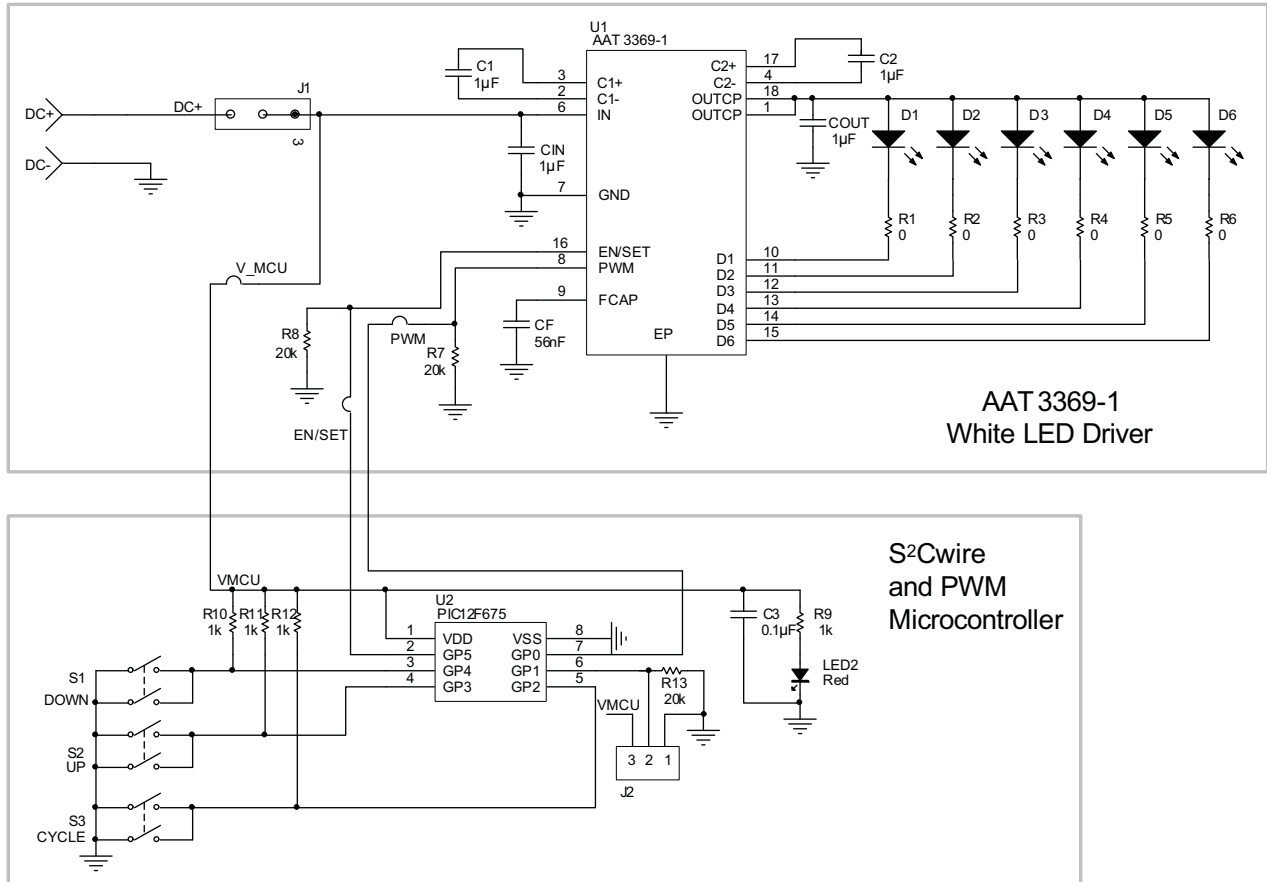

Figure 6: AAT3369-1 Evaluation Board Schematic.

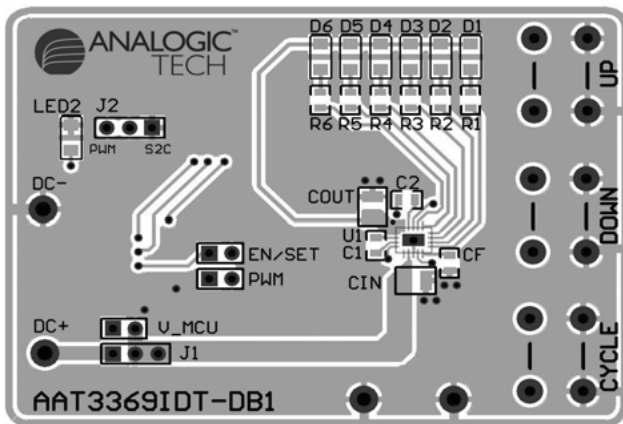

Figure 7: AAT3369-1 Evaluation Board Top Side Layout.

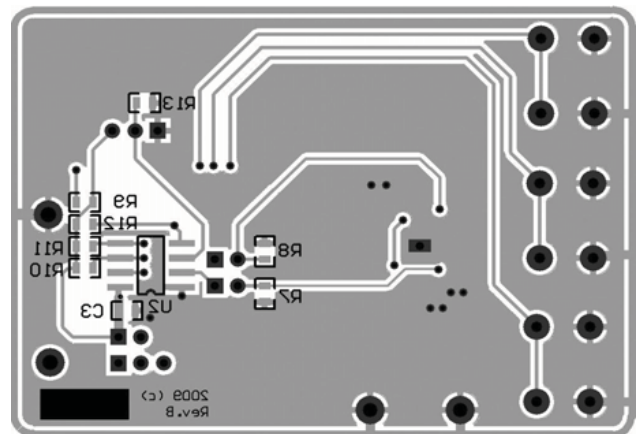

Figure 8: AAT3369-1 Evaluation Board Bottom Side Layout.

ChargePump™ High Efficiency, 6 Channel, 1X/1.5X Charge Pump for White LED Applications

Component	Part Number	Description	Manufacturer
U1	AAT3369IDT-1	High Efficiency, 6 Channel, 1X/1.5X Charge Pump for White LED Driver	AnalogicTech
U2	PIC12F675	8-Pin Flash-Based 8-Bit CMOS Microcontrollers	Microchip
R1, R2, R3, R4, R5, R6	RC0603FR-070RL	Res 0Ω 1/10W 1% 0603 SMD	Yageo
R7, R8, R13	RC0603FR-0720KL	Res 20kΩ 1/10W 1% 0603 SMD	
R9, R10, R11, R12	RC0603FR-071KL	Res 1kΩ 1/10W 1% 0603 SMD	
C1, C2, CIN, COUT	GRM188R71C105K	Cap Ceramic 1μF 0603 X7R 16V 10%	Murata
C3	GRM188R71C104K	Cap Ceramic 0.1μF 0603 X7R 16V 10%	
C _F	GRM188R71C563K	Cap Ceramic 56nF 0603 X7R 16V 10%	
D1, D2, D3, D4, D5, D6	RS-0805UW	20mA White LED 0805	Realstar
LED2	0805KRCT	Red LED 0805	HB
CYCLE, UP, DOWN	6*6*5	12V 50mA Pushbutton	E-LT

Table 3: AAT3369-1 Evaluation Board Bill of Materials (BOM).

ChargePump™ High Efficiency, 6 Channel, IX/1.5X Charge Pump for White LED Applications

Ordering Information

Package	Part Marking ¹	Part Number (Tape and Reel) ²
TQFN3x2.2-18L	9NXXY	AAT3369IDT-1-T1



All AnalogicTech products are offered in Pb-free packaging. The term “Pb-free” means semiconductor products that are in compliance with current RoHS standards, including the requirement that lead not exceed 0.1% by weight in homogeneous materials. For more information, please visit our website at <http://www.analogictech.com/aboutus/quality.php>.

Package Information

TQFN3x2.2-18³

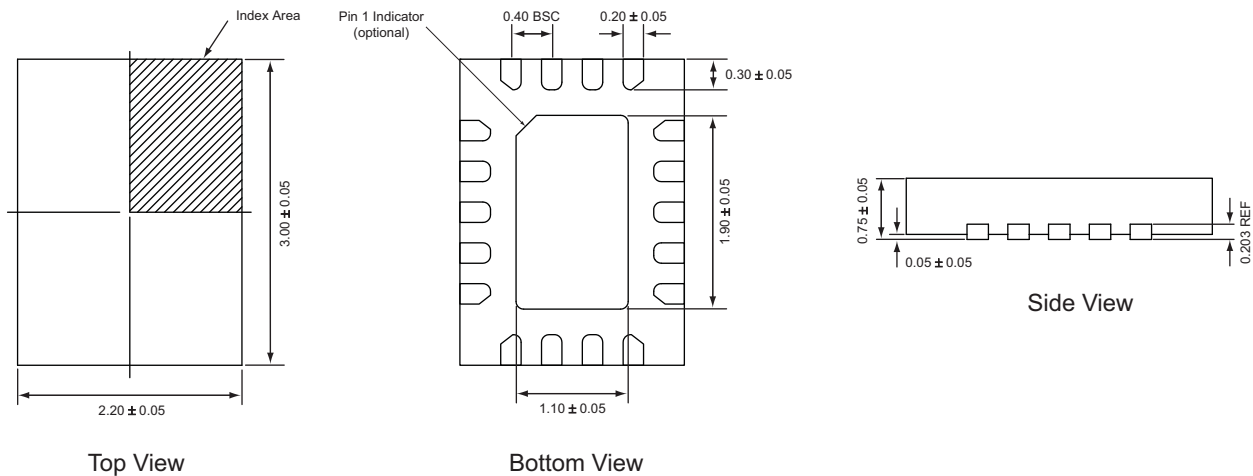

All dimensions in millimeters.

1. XYY = assembly and date code.
2. Sample stock is generally held on part numbers listed in **BOLD**.
3. The leadless package family, which includes QFN, TQFN, DFN, TDFN and STDFN, has exposed copper (unplated) at the end of the lead terminals due to the manufacturing process. A solder fillet at the exposed copper edge cannot be guaranteed and is not required to ensure a proper bottom solder connection.

Advanced Analogic Technologies, Inc.
 3230 Scott Boulevard, Santa Clara, CA 95054
 Phone (408) 737-4600
 Fax (408) 737-4611



© Advanced Analogic Technologies, Inc. AnalogicTech cannot assume responsibility for use of any circuitry other than circuitry entirely embodied in an AnalogicTech product. No circuit patent licenses, copyrights, mask work rights, or other intellectual property rights are implied. AnalogicTech reserves the right to make changes to their products or specifications or to discontinue any product or service without notice. Except as provided in AnalogicTech's terms and conditions of sale, AnalogicTech assumes no liability whatsoever, and AnalogicTech disclaims any express or implied warranty relating to the sale and/or use of AnalogicTech products including liability or warranties relating to fitness for a particular purpose, merchantability, or infringement of any patent, copyright or other intellectual property right. In order to minimize risks associated with the customer's applications, adequate design and operating safeguards must be provided by the customer to minimize inherent or procedural hazards. Testing and other quality control techniques are utilized to the extent AnalogicTech deems necessary to support this warranty. Specific testing of all parameters of each device is not necessarily performed. AnalogicTech and the AnalogicTech logo are trademarks of Advanced Analogic Technologies Incorporated. All other brand and product names appearing in this document are registered trademarks or trademarks of their respective holders.